

SERAPHIM DG AND BG PHOTOVOLTAIC MODULE



SERAPHIM ENERGY GROUP CO. LTD

ADDRESS: Intersection of baimafeng road and Weimin Road,

Jinzhai County, Lu'an City, Anhui Province

TELEPHONE: +86-0564-7736177

MAILBOX: info@seraphim-energy.com

Version: 2025V1.0

CONTENTS

1 PURPOSE OF THIS GUIDE	1
1.1 APPLICABLE PRODUCTS.....	1
2 SAFETY.....	2
2.1 GENERAL SAFETY.....	2
2.2 HANDLING SAFETY	3
2.3 INSTALLATION SAFETY.....	3
2.4 FIRE SAFETY	5
3 PRODUCT IDENTIFICATION	5
4 MECHANICAL INSTALLATION.....	5
4.1 GENERAL INSTALLATION PRINCIPLE.....	5
4.2 LOCATION AND ANGLE SELECTION	6
4.3 MOUNTING WITH CLAMPS	6
4.3.1 Install module with clamps at long sides of frames.....	8
4.3.2 Install module with clamps at short side of frames	10
4.4 SCREW INSTALLATION	11
4.5 Tracker Installation.....	13
4.6 CLAMP INSTALLATION	15
4.7 ELECTRICAL INSTALLATION.....	16
4.8 GROUNDING.....	18
5 MAINTENANCE.....	18
5.1 Cleaning	18
5.2 Appearance Inspection of PV Modules	19
5.3 Inspection of Connectors and Cables	19
6 PARAMETERS	19
ATTACHMENT 1.....	21
INSTRUCTIONS FOR USE OF CONVERSION CABLES.....	21

1 PURPOSE OF THIS GUIDE

We would like to express our sincerest gratitude for choosing Seraphim Photovoltaic Modules (hereafter referred to as “PV Module”), this guide provides detailed information on proper application and installation of Seraphim PV modules. Installers must read, understand, and apply the following guideline ensuring compliance for any installation activities carried out. For any enquiries, please contact our technical department (technic@seraphim-energy.com) for further information. Installers should follow all safety precautions described in this Guide, best industrial practices, as well as local code of conduct during installation of PV module. It is advisable to keep a copy of this Guide at a safe place for on-site reference (operation and maintenance) in case of O&M activities or disposal activities of PV modules. Please do not step, stand, or sit on PV modules while conducting installing or cleaning activities.



1.1 APPLICABLE PRODUCTS

This document is applicable to the following series of PV modules:

	Module type	Module size
Bifacial module	SRP-XXX-6PA-DG, SRP-XXX-6MA-DG/BG	1986*996
	SRP-XXX-6PA-DG, SRP-XXX-6MA-DG/BG	2010*1008
	SRP-XXX-6PB-DG, SRP-XXX-6MB-DG/BG	1664*998
	SRP-XXX-6PB-DG, SRP-XXX-6MB-DG/BG	1690*1008
	SRP-XXX-BPA-DG, SRP-XXX-BMA-DG/BG	2045*1008
	SRP-XXX-BPA-DG, SRP-XXX-BMA-DG/BG	2094*1038
	SRP-XXX-BPB-DG, SRP-XXX-BMB-DG/BG	1720*1008
	SRP-XXX-BPB-DG, SRP-XXX-BMB-DG/BG	1755*1038
	SRP-XXX-BMC-BG	1852*1002
	SRP-XXX-BMZ-BG	2198*1008
	SRP-XXX-BMA-DG/BG, SRP-XXX-BTA-BG	2278*1134
	SRP-XXX-BMB-DG/BG, SRP-XXX-BTB-BG	1909*1134
	SRP-XXX-BMC-DG/BG, SRP-XXX-BTC-BG	2093*1134
	SRP-XXX-BMD-DG/BG, SRP-XXX-BTD-BG	1722*1134

	SRP-XXX-BMZ-DG/BG, SRP-XXX-BTZ-BG	2465*1134
	SRP-XXX-BTB-BG	2172*1134
	SRP-XXX-BTC-BG	2382*1134
	SRP-XXX-BTD-BG	1962*1134
	SRP-XXX-BTE-BG	1762*1134
	SRP-XXX-BTF-BG	1540*1134
	SRP-XXX-BMB-BG, SRP-XXX-BTB-BG, SRP-XXX-BHB-BG	2172*1303
	SRP-XXX-BMC-BG, SRP-XXX-BTC-BG, SRP-XXX-BHC-BG	2384*1303

-DG Module: Single side dual-glass module

-BG Module: Bifacial dual-glass module

XXX: Module power class.

Table 1: Seraphim's PV module product range

2 SAFETY

2.1 GENERAL SAFETY

- The PV modules are qualified for class A compliance application for spread of flame, which may be used in systems operating at greater than 50 V DC or 240 W, where general contact access is anticipated. PV modules qualified for safety through this part of IEC 61730 and IEC 61730-2 and within this application class are considered meeting the requirements for safety class II.
- The PV modules must be properly grounded in accordance with the instructions underline this Guide or the requirements of country specific National Electrical Code.
- Installation of PV modules require specialized skills and knowledge. Installation should only be performed by qualified personnel or professionals, and electrical connections require licensed electrician, where applicable according to local code of conduct and regulations (i.e. the NEC for the USA and CEC for Canada).
- Installers should take into consideration of all the risks of injury occurrence during installation, including, especially the risk of electric shock.
- One single PV module generates more than 30V DC when exposed to direct sunlight. Access to a DC voltage of 30V or more is potentially hazardous.
- PV modules convert light irradiation to DC electrical energy, which are designed for outdoor use. PV modules can be mounted onto ground, rooftop, vehicles or boats etc. The proper design of support structures falls under the responsibility of the system designers and installers.

- Do not use mirrors or other form of magnifiers to concentrate sunlight onto the PV modules.
- When installing the PV modules, abide to all local, regional and national statutory regulations. Obtain a building permit if necessary.
- Only use equipment, connectors, wiring, and support frames that are compatible with the PV modules to reduce the mismatch inflicted fire and electrical risks.
- Do not clean the PV modules with chemicals or non-alcoholic solvents with high concentration of minerals.

2.2 HANDLING SAFETY

- Do not carry PV modules by gripping the junction box or cables.
- Do not stand onto or place heavy objects onto the PV modules.
- Do not drop PV modules or allow objects to fall onto them.
- Handle PV modules with care during moving, transportation, and installation.
- Do not attempt to disassemble PV modules or remove any attached nameplates or components.
- Do not apply paint or adhesive to the PV module's surface.
- Do not scratch or damage the PV module's backsheets.
- Do not drill holes onto the PV module's anodized frame, as this will reduce its mechanical strength and may cause cell microcracks due to vibration as well as damaging the anodization inflicting accelerated aging or rusting of anodized aluminum frame.
- Do not damage the anodization layer of the frame surface (except for grounding purposes), as this may lead to frame corrosion.
- Do not use PV modules with broken glass or torn backsheets due to the risk of electric shock.
- Do not handle PV modules in wet conditions unless appropriate safety measures are taken.
- Do not expose PV modules under sunlight before installation to avoid unnecessary weather inflicted degradation.
- During all handling and transportation processes, ensure that PV modules are not subjected to severe vibrations, as this may cause internal cell microcracks or damage to the PV modules.

2.3 INSTALLATION SAFETY

- Installation work should comply to IEC standards and electrical installation safety standards.
- Do not disconnect PV modules under load.
- Do not touch the conductive parts of the PV modules, whether connected or not, as it may cause arc sparks, burns,

and fatal electric shock.

- Do not touch PV modules unnecessarily during installation.
- Do not install PV modules under rainy, snowy, or windy weather.
- Do not expose PV modules to artificial light; cover the entire module surface with opaque materials during installation to prevent current generation.
- Do not wear metal rings, watchbands, ear, nose, lip rings, or other metal accessories during installation and maintenance of PV modules.
- Use only insulated tools approved for electrical installation work.
- Follow all safety regulations for each of the balance of system accessories, including cables, connectors, charge controllers, inverters, batteries, rechargeable batteries, etc during installation.
- Under normal outdoor conditions, the current and short-circuit current generated by PV modules may differ from the data in the product specification sheet. When designing the system, multiply the current and short-circuit current by a factor of 1.25 as reference value for current carrying capacity for the balance of systems accessories selection.
- Use only connectors compatible with the PV module's connectors to prevent mismatch inflicted PV fire as risk mitigation plan; unauthorized disassembly of connectors will result in voidance of warranty.
- Do not disassemble installed PV modules for use in other projects, as this may results in voidance of warranty.
- Do not install PV modules within 50m near coastline or onto still water reservoir with pH range outside of 6.5 – 8.5. For installation located near coastal area at sea water with high salt mist occurrence, an additional cost adder to 15-micron anodization coating for C5 environment is required for salt mist induced corrosion mitigation deemed required. PV module must be erected onto fixed tilt float where lowest point of module does not pose any risk of direct contact with sea water.
- For floating solar installation at coastal line, accelerated aging due to salt mist corrosion onto the anodization of PV modules' frame and early delamination will not fall under responsibility of Seraphim's standard warranty.

Item	Distance from Sea	Installation	Maintenance Measures	Warranty Guarantee
1.	≥500m	Normal	General Measures	Under Warranty
2.	50m < Distance < 500m	Additional Corrosion Protection	Additional Measures	Under Warranty
3.	≤50m	Not advisable	-	-

Table 2 Seraphim PV Module Products Coastal Distance Installation Table

2.4 FIRE SAFETY

- The fire safety compliance of this PV module is only deemed valid upon which this Guide is strictly followed.
- Consult your local authority for Guidelines and requirements for building or structural fire safety ensure installation compliance.
- Do not use PV modules near equipment or in places where flammable gases may present or being generated.
- Follow local code of conduct and regulation when installing PV modules.

3 PRODUCT IDENTIFICATION

Each module has two Barcode stickers which have the identical unique serial No. representing each module and one label sticker:

Barcode 1: Laminated into PV modules.

Barcode 2: Stick on the backside of PV modules.

Barcode 3: Stick on the middle section of long side of anodized aluminum frame.

Label: Sticked on the rear side of PV modules, containing electrical characteristics parameters of the PV modules.

Check the serial No. on the barcode with the packing list during unpacking. Provide PV module serial No. when you need support from SERAPHIM on specific PV modules.

4 MECHANICAL INSTALLATION

4.1 GENERAL INSTALLATION PRINCIPLE

- PV module can be installed in both landscape and portrait orientation.
- The clamps shall not shade the front side of the cells.
- The PV modules shall be installed high enough to keep it away from potential nearby shading, flying sands, snow and water.
- It is recommended to install the PV modules 40cm above ground finishing level to ensure ventilation channel for ventilation consideration.
- It is recommended to install the bifacial modules 1m above ground finishing level or 50mm above ridges of metal deck roof to maintain the energy yield of module rear side.
- Appropriate mounting structures shall be selected to meet required mechanical load.
- It is recommended to install the PV modules with minimum tilt angle of 10 degrees to ease the dust to be washed off easily upon rainfall.

- It is recommended to keep minimum 2cm gap between PV modules for thermal expansion buffer of materials.
- Install PV modules appropriately according to clamping zone compliance corresponding to mechanical load required.
- Although PV modules have passed the IEC 61701 salt-mist criteria, but galvanic corrosion can still occur between the aluminum frame of the modules and mounting or grounding hardware if such hardware comprises of different metallic properties. PV modules can be installed at coastal location 50m to 500m from the sea, but the components should be sufficiently protected against corrosion.

4.2 LOCATION AND ANGLE SELECTION

- It is recommended to install PV modules at collector plane with excellent sunlight irradiation. In the Northern Hemisphere, the module should typically face south, likewise in the Southern Hemisphere, the modules should typically face north. The optimum installation angle varies according to different latitudes and longitudes; please consult experts with appropriate design knowledge when determining the installation locations and tilt angles.
- When choosing a suitable installation location, avoid trees, buildings or obstructions, which could cast shadows on the solar photovoltaic modules. Shading causes hotspot development and loss of output, even though bypass diodes on the PV modules were deployed to minimize such effect.
- Do not install the PV module near open flame location or flammable materials.
- Do not install PV module at a location with risk of water immersion or constantly exposed to water from a sprinkler or fountain etc.

4.3 MOUNTING WITH CLAMPS

The dual glass module with frame is designed for clamp installation. It needs the clamps, bolts, nuts, and washers to be fixed onto the bracket (as shown in figure 3 and figure 4). Sufficient torque should be applied to the bolts to ensure sufficient reinforcement applied. The reference torque magnitude for M8 screw is 16~20N*M. It is recommended to use a fixture that can hold the M8 bolt at least, with corresponding spring gaskets. Figure 1 and Figure 2 show two different types of press blocks:



Figure 1 Single-side clamp



Figure 2 Double-side clamp

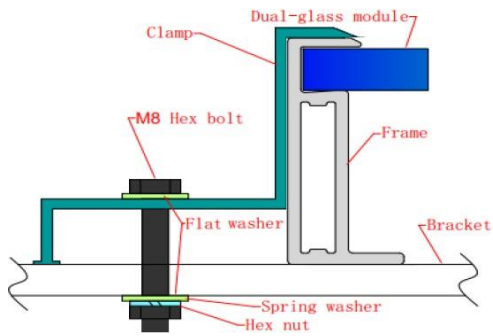

Figure 3 Single-side clamp installation

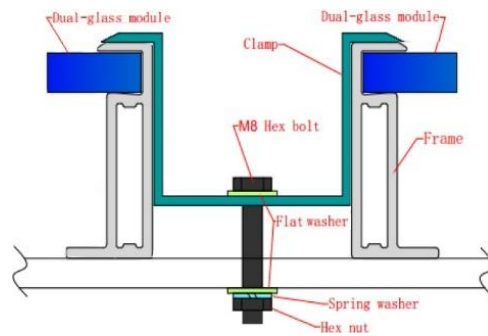
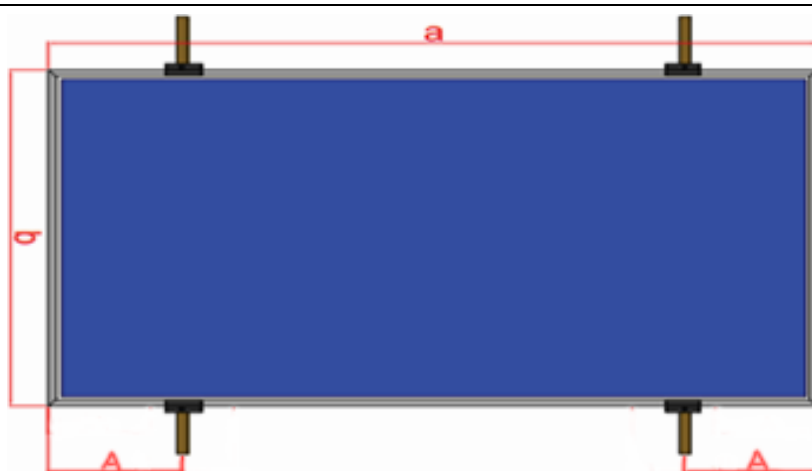

Figure 4 Double-side clamp installation

To ensure that the modules can withstand a downward force of up to 5400 Pa (550 kg/m²), the modules shall be fixed on the bracket at the long side of the module, using minimum of four clamps. Please make sure to use at least of two purlins behind the modules to support the modules.

4.3.1 Install module with clamps at long sides of frames

 Clamp length ≥ 50 mm

Bifacial Module	Module type	Module size a*b	Mechanical loads (Pa)
	SRP-XXX-6PA-DG SRP-XXX-6MA-DG/BG	1986*996	A=(300-500)mm Downforce load \leq 5400Pa; Uplift load \leq 2400Pa A=(50-500)mm Downforce load \leq 2400Pa; Uplift load \leq 2400Pa
	SRP-XXX-6PA-DG SRP-XXX-6MA-DG/BG	2010*1008	
	SRP-XXX-6PB-DG SRP-XXX-6MB-DG/BG	1664*998	
	SRP-XXX-6PB-DG SRP-XXX-6MB-DG/BG	1690*1008	A=(380-580)mm Downforce load \leq 5400Pa; Uplift load \leq 2400Pa A=(50-580)mm Downforce load \leq 2400Pa; Uplift load \leq 2400Pa
	SRP-XXX-BPA-DG SRP-XXX-BMA-DG/BG	2045*1008	
	SRP-XXX-BPA-DG SRP-XXX-BMA-DG/BG	2094*1038	A=(300-500)mm Downforce load \leq 5400Pa; Uplift load \leq 2400Pa A=(50-500)mm Downforce load \leq 2400Pa; Uplift load \leq 2400Pa
	SRP-XXX-BPB-DG SRP-XXX-BMB-DG/BG	1720*1008	
	SRP-XXX-BPB-DG SRP-XXX-BMB-DG/BG	1755*1038	A=(300-500)mm Downforce load \leq 5400Pa; Uplift load \leq 2400Pa A=(50-500)mm Downforce load \leq 2400Pa; Uplift load \leq 2400Pa
	SRP-XXX-BMC-BG	1852*1002	
	SRP-XXX-BMZ-BG	2198*1008	A=(380-580)mm Downforce load \leq 5400Pa; Uplift load \leq 2400Pa A=(50-580)mm Downforce load \leq 2400Pa; Uplift load \leq 2400Pa
	SRP-XXX-BMA-DG/BG SRP-XXX-BTA-BG	2278*1134	

SRP-XXX-BMB-DG/BG SRP-XXX-BTB-BG	1909*1134	A=(300-500)mm Downforce load \leq 5400Pa; Uplift load \leq 2400Pa A=(50-500)mm Downforce load \leq 2400Pa; Uplift load \leq 2400Pa
SRP-XXX-BMC-DG/BG SRP-XXX-BTC-BG	2093*1134	A=(300-500)mm Downforce load \leq 5400Pa; Uplift load \leq 2400P
SRP-XXX-BMD-DG/BG SRP-XXX-BTD-BG	1722*1134	A=(300-500)mm Downforce load \leq 5400Pa; Uplift load \leq 2400Pa
SRP-XXX-BMZ-DG/BG SRP-XXX-BTZ-BG	2465*1134	A=(450-650)mm Downforce load \leq 5400Pa; Uplift load \leq 2400Pa A=(100-650)mm Downforce load \leq 2400Pa; Uplift load \leq 2400Pa
SRP-XXX-BTB-BG	2172*1134	A=(300-550)mm Downforce load \leq 5400Pa; Uplift load \leq 2400Pa
SRP-XXX-BTC-BG	2382*1134	A=(420-520)mm Downforce load \leq 5400Pa; Uplift load \leq 2400Pa
SRP-XXX-BTD-BG	1962*1134	A=(300-550)mm Downforce load \leq 5400Pa; Uplift load \leq 2400Pa
SRP-XXX-BTE-BG	1762*1134	A=(220-450)mm Downforce load \leq 5400Pa; Uplift load \leq 2400Pa
SRP-XXX-BTF-BG	1540*1134	A=(200-400)mm Downforce load \leq 5400Pa; Uplift load \leq 2400Pa
SRP-XXX-BMB-BG SRP-XXX-BTB-BG SRP-XXX-BHB-BG	2172*1303	A=(250-440)mm Downforce load \leq 2400Pa; Uplift load \leq 1800Pa
SRP-XXX-BMC-BG SRP-XXX-BTC-BG SRP-XXX-BHC-BG	2384*1303	A=(280-480)mm Downforce load \leq 2400Pa; Uplift load \leq 1800Pa

* Any frame that is not delimited defaults to regular borders.

Table 3 Long-side Installation Diagram and Mechanical Loads

In addition, to ensure the reliability of the 210mm module installation against mechanical loads we used three mounting brackets:

Bifacial module			
	Module type	Module size a*b	Mechanical loads (Pa)
	SRP-XXX-BMB-BG SRP-XXX-BTB-BG SRP-XXX-BHB-BG	2172*1303	A=(250-440)mm B=(50-100)mm Downforce load ≤ 5400Pa; Uplift load ≤ 2400Pa
	SRP-XXX-BMC-BG SRP-XXX-BTC-BG SRP-XXX-BHC-BG	2384*1303	A=(280-480)mm B=(50-100)mm Downforce load ≤ 5400Pa; Uplift load ≤ 2400Pa

Table 4 Schematic diagram of long-edge installation and mechanical load for large-format modules

4.3.2 Install module with clamps at short side of frames

Bifacial module			
	Module type	Module size e*d	Mechanical loads (Pa)

	SRP-XXX-BMA-DG/BG SRP-XXX-BTA-BG	2278*1134	A=(100-240)mm Downforce load≤1600Pa; Uplift load≤1600Pa
	SRP-XXX-BMB-DG/BG SRP-XXX-BTB-BG	1909*1134	
	SRP-XXX-BMC-DG/BG SRP-XXX-BTC-BG	2093*1134	
	SRP-XXX-BMD-DG/BG SRP-XXX-BTD-BG	1722*1134	
	SRP-XXX-BMZ-DG/BG SRP-XXX-BTZ-BG	2465*1134	
	SRP-XXX-BTB-BG	2172*1134	
	SRP-XXX-BTC-BG	2382*1134	
	SRP-XXX-BTD-BG	1962*1134	
	SRP-XXX-BTE-BG	1762*1134	
	SRP-XXX-BTF-BG	1540*1134	

Table 5 Schematic diagram of short-edge installation and mechanical load

4.4 SCREW INSTALLATION

Another installation method for framed double-glass modules is screw installation. This method requires the use of structural components such as bolts, nuts, spring washers, and flat washers to secure the modules to the mounting brackets. Sufficient torque should be applied to the bolts to ensure stable fastening. The recommended torque magnitude for M8 screws is 16~20Nm.

Bifacial module	 (8 mounting holes suitable for frame with 8 mounting holes design)			 (4 mounting holes suitable for frame with 4 mounting holes design)		
	Module type	Module size	Mechanical loads (Pa)	Module type	Module size	Mechanical loads (Pa)
SRP-XXX-6PA-DG SRP-XXX-6MA-DG/BG	1986*996	Downforce load≤5400Pa Uplift load≤2400Pa	SRP-XXX-6PA-DG SRP-XXX-6MA-DG/BG	1986*996	Downforce load≤2400Pa Uplift load≤2400Pa	
SRP-XXX-6PA-DG SRP-XXX-6MA-DG/BG	2010*1008		SRP-XXX-6PA-DG SRP-XXX-6MA-DG/BG	2010*1008		
SRP-XXX-6PB-DG SRP-XXX-6MB-DG/BG	1664*998		SRP-XXX-6PB-DG SRP-XXX-6MB-DG/BG	1664*998		
SRP-XXX-6PB-DG	1690*1008		SRP-XXX-6PB-DG	SRP-XXX-6PB-DG		
			SRP-XXX-6PB-DG	SRP-XXX-6PB-DG		

SRP-XXX-6MB-DG/BG			SRP-XXX-6MB-DG/BG		
SRP-XXX-BPA-DG SRP-XXX-BMA-DG/BG	2045*1008		SRP-XXX-BPA-DG SRP-XXX-BMA-DG/BG	2045*1008	
SRP-XXX-BPA-DG SRP-XXX-BMA-DG/BG	2094*1038		SRP-XXX-BPA-DG SRP-XXX-BMA-DG/BG	2094*1038	
SRP-XXX-BPB-DG SRP-XXX-BMB-DG/BG	1720*1008		SRP-XXX-BPB-DG SRP-XXX-BMB-DG/BG	1720*1008	
SRP-XXX-BPB-DG SRP-XXX-BMB-DG/BG	1755*1038		SRP-XXX-BPB-DG SRP-XXX-BMB-DG/BG	1755*1038	
SRP-XXX-BMC-BG	1852*1002		SRP-XXX-BMC-BG	1852*1002	
SRP-XXX-BMZ-BG	2198*1008		SRP-XXX-BMZ-BG	2198*1008	
SRP-XXX-BMA-DG/BG SRP-XXX-BTA-BG	2278*1134		SRP-XXX-BMA-DG/BG SRP-XXX-BTA-BG	2278*1134	
SRP-XXX-BMB-DG/BG SRP-XXX-BTB-BG	1909*1134		SRP-XXX-BMB-DG/BG SRP-XXX-BTB-BG	1909*1134	
SRP-XXX-BMC-DG/BG SRP-XXX-BTC-BG	2093*1134		SRP-XXX-BMC-DG/BG SRP-XXX-BTC-BG	2093*1134	
SRP-XXX-BMD-DG/BG SRP-XXX-BTD-BG	1722*1134	/	SRP-XXX-BMD-DG/BG SRP-XXX-BTD-BG	1722*1134	Downforce load ≤ 2400Pa Uplift load ≤ 2400Pa
SRP-XXX-BMZ-DG/BG SRP-XXX-BTZ-BG	2465*1134	Downforce load ≤ 5400Pa Uplift load ≤ 2400Pa	SRP-XXX-BMZ-DG/BG SRP-XXX-BTZ-BG	2465*1134	Downforce load ≤ 2400Pa Uplift load ≤ 2400Pa
SRP-XXX-BTB-BG	2172*1134		SRP-XXX-BTB-BG	2172*1134	
SRP-XXX-BTC-BG	2382*1134		SRP-XXX-BTC-BG	2382*1134	
SRP-XXX-BTD-BG	1962*1134		SRP-XXX-BTD-BG	1962*1134	
SRP-XXX-BTE-BG	1762*1134		SRP-XXX-BTE-BG	1762*1134	
SRP-XXX-BTF-BG	1540*1134		SRP-XXX-BTF-BG	1540*1134	
SRP-XXX-BMB-BG SRP-XXX-BTB-BG SRP-XXX-BHB-BG	2172*1303		SRP-XXX-BMB-BG SRP-XXX-BTB-BG SRP-XXX-BHB-BG	2172*1303	
SRP-XXX-BMC-BG SRP-XXX-BTC-BG SRP-XXX-BHC-BG	2384*1303		SRP-XXX-BMC-BG SRP-XXX-BTC-BG SRP-XXX-BHC-BG	2384*1303	

Table 6 Schematic diagram of screw installation and mechanical load

The details information on screw type installation are illustrated in Figure 5. To ensure that the module can withstand desired mechanical loads, at least four screws should be used to secure the module to the mounting bracket at the long edge. During installation, it must be ensured that at least two supporting rails are perpendicular to the back of the module to provide sufficient support.

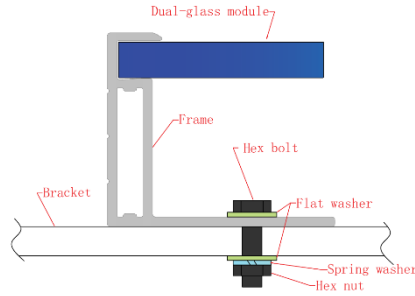

Figure 5 Schematic diagram of screw installation

The recommended accessories are shown in the following Table 7.:

1. Bolt	2. Washer	3. Spring Washer	4. Nut
Size and Length: M8*16mm/M6*16mm	Size: M8/M6, thickness $\geq 1.5\text{mm}$, outside diameter $\leq 16\text{mm}$	Size: M8/M6	Size: M8/M6

Recommended torque is between 12N.m to 16N.m.

Recommendations: 1. M8 screw tightening torque size range: 12-16N.M; M6 screw tightening torque size range: 8-12N.M., 2. For 30mm frame, it is recommended to choose screw. $L \leq 20\text{mm}$ length fasteners.

Table 7 Recommended screw accessories table

4.5 Tracker Installation

The bolts used in this section is to secure the module in each fixing location with an M6/M8 bolt, two flat washers, a spring washer and a nut, and tighten them to a torque of 10-14 Nm, it is recommended to take regular inspection on the tightening to meet the recommended torque range. For all products covered in this section, all parts in contact with the frame should use flat stainless-steel washers of minimum 1.5mm (0.06 inch) thickness with an outer diameter of 16-18mm (0.63- 0.71 inch). The module must be installed on the purlins:

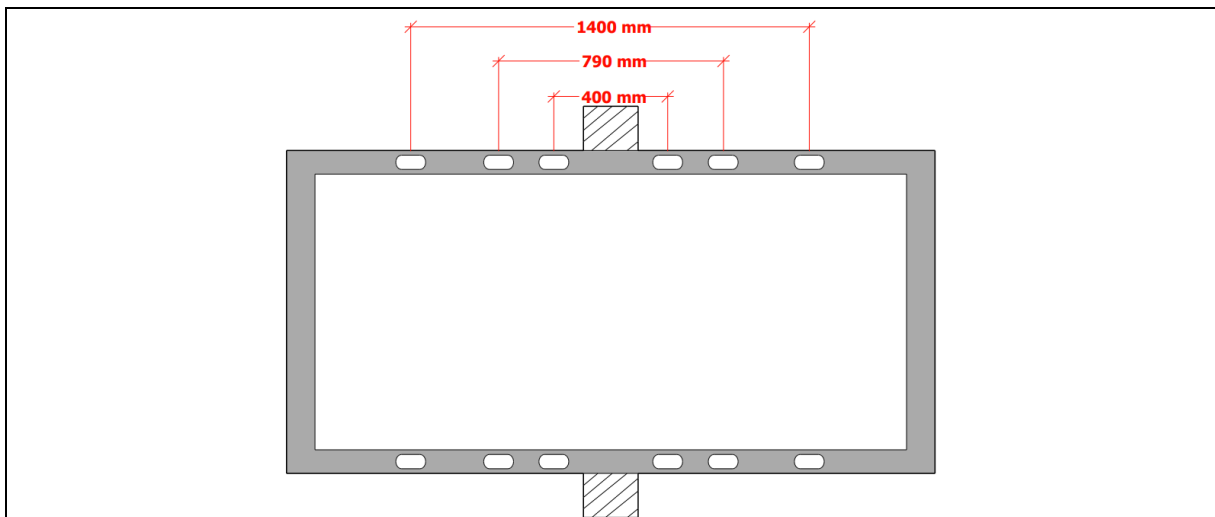

Mounting rails run perpendicular to the long side frame. Distance between mounting holes is 400mm/790mm/1400mm.

Bifacial module	Module type	Module size	Tracker system	Installation	Mechanical loads (Pa)
	SRP-XXX-BMA-BG SRP-XXX-BTA-BG	2278*1134	NX Tracker 2.4	hole distance 400mm Hole spacing 1084mm	Downforce load $\leq 2400\text{Pa}$ Uplift load $\leq 2400\text{Pa}$

				Short rail 85x1430x1.5 hole distance 1400mm Hole spacing 1084mm	Downforce load \leq 3000Pa Uplift load \leq 2400Pa
SRP-XXX-BTZ-BG SRP-XXX-BMZ-BG	2465*1134	NX Tracker 2.4	hole distance 400mm Hole spacing 1096mm	Downforce load \leq 1800Pa Uplift load \leq 1800Pa	
			Short rail 85x1430x1.5 hole distance 1600mm Hole spacing 1096mm	Downforce load \leq 2100Pa Uplift load \leq 2100Pa	
SRP-XXX-BTC-BG	2382*1134	NX Tracker 2.4	hole distance 400mm Hole spacing 1084mm	Downforce load \leq 2400Pa Uplift load \leq 2400Pa	
			Short rail 85x1430x1.5 hole distance 1400mm Hole spacing 1084mm	Downforce load \leq 3000Pa Uplift load \leq 2400Pa	
SRP-XXX-BMC-BG SRP-XXX-BTC-BG SRP-XXX-BHC-BG	2384*1303	NX Tracker 2.4	hole distance 400mm Hole spacing 1264mm	Downforce load \leq 1800Pa Uplift load \leq 1800Pa	
			Short rail 85x1430x1.5 hole distance 1400mm Hole spacing 1264mm	Downforce load \leq 2100Pa Uplift load \leq 2100Pa	
SRP-XXX-BMA-BG SRP-XXX-BTA-BG	2278*1134	PVH 1P	hole distance 400mm Hole spacing 1100mm	Downforce load \leq 2400Pa Uplift load \leq 1200Pa	
			Short rail 85x1430x1.5 hole distance 1400mm Hole spacing 1100mm	Downforce load \leq 3600Pa Uplift load \leq 1800Pa	
SRP-XXX-BMA-BG	2094*1038	NX Tracker 2.4	hole distance 400mm Hole spacing 996mm	Downforce load \leq 1800Pa Uplift load \leq 1800Pa	
			Short rail 85x1430x1.5 hole distance 934mm Hole spacing 996mm	Downforce load \leq 2400Pa Uplift load \leq 2400Pa	

Table 8 Mechanical loads for different module models installed on different tracking bracket systems

4.6 CLAMP INSTALLATION

The installation method for frameless double-glass modules is clamp installation, which requires the use of clamps with rubber strips to secure the modules to the mounting brackets. Figure 6 and Figure 7 show diagrams of two distinct types of clamps.

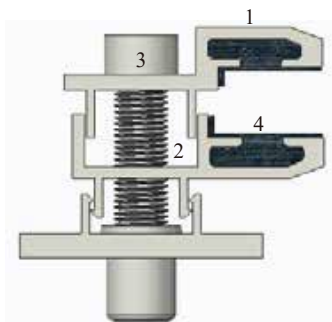

Figure 6 Single-side clamp

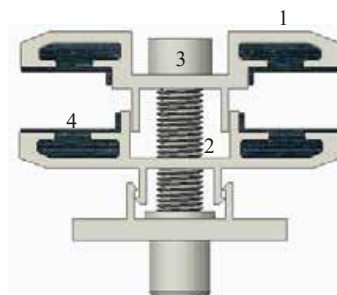

Figure 7 Double-side clamp

NO.	Name	Remark
1	Aluminium alloy	6063-T5
2	Spring	/
3	Bolt	M8 stainless steel bolt
4	Rubber strip	Ethylene Propylene Diene Monomer (EPDM)

Table 9 Components of the clamp

To ensure that the PV modules can withstand a downward force of up to 2400 Pa (244 kg/m²), the modules shall be fixed onto bracket at the long side of the module, using a minimum of four clamps per PV module. Please make sure to use at least of two purlins behind the modules to support the modules.

The applied torque should be sufficient to fix it steadily. The reference torque magnitude for screw is 16~20Nm.

Bifacial module	Clamp Length ≥ 150 mm			Clamp Length ≥ 200 mm		
	Module type	Module size	Mechanical loads (Pa)	Module type	Module size	Mechanical loads (Pa)
	SRP-XXX-6PA-DG SRP-XXX-6MA-DG/BG	1986*996	/	SRP-XXX-6PA-DG SRP-XXX-6MA-DG/BG	1986*996	A=(250-350)mm Downforce load ≤ 2400 Pa Uplift load ≤ 2400 Pa
	SRP-XXX-6PA-DG SRP-XXX-6MA-DG/BG	2010*1008		SRP-XXX-6PA-DG SRP-XXX-6MA-DG/BG	2010*1008	
	SRP-XXX-6PB-DG SRP-XXX-6MB-DG/BG	1664*998	A=(350-450)mm Downforce load ≤ 2400 Pa Uplift load ≤ 2400 Pa	SRP-XXX-6PB-DG SRP-XXX-6MB-DG/BG	1664*998	/
	SRP-XXX-6PB-DG SRP-XXX-6MB-DG/BG	1690*1008	SRP-XXX-6PB-DG SRP-XXX-6MB-DG/BG	1690*1008		
	SRP-XXX-BPA-DG SRP-XXX-BMA-DG/BG	2045*1008	/	SRP-XXX-BPA-DG SRP-XXX-BMA-DG/BG	2045*1008	A=(250-350)mm Downforce load ≤ 2400 Pa Uplift load ≤ 2400 Pa
	SRP-XXX-BPA-DG SRP-XXX-BMA-DG/BG	2094*1038		SRP-XXX-BPA-DG SRP-XXX-BMA-DG/BG	2094*1038	
	SRP-XXX-BPB-DG SRP-XXX-BMB-DG/BG	1720*1008	A=(350-450)mm Downforce load ≤ 2400 Pa Uplift load ≤ 2400 Pa	SRP-XXX-BPB-DG SRP-XXX-BMB-DG/BG	1720*1008	/
	SRP-XXX-BPB-DG SRP-XXX-BMB-DG/BG	1755*1038	SRP-XXX-BPB-DG SRP-XXX-BMB-DG/BG	1755*1038		

Table 10 Schematic diagram of installation and mechanical load

4.7 ELECTRICAL INSTALLATION



WARNING Electrical Hazard
This module produces electricity when exposed to light. Follow all applicable electrical safety precautions.

- ONLY qualified personnel or professionals can install or perform maintenance work on these PV modules.
- BE AWARE of dangerous high DC voltage when connecting module.
- DO NOT damage or scratch the rear surface of the module.
- DO NOT install module when they are wet.
- The wiring components selected for installation shall be compatible with the PV modules specification with minimum mismatch impact.
- The PV modules connected in series shall have similar current. The Voc of one PV string must not be higher than

the maximum system voltage, the Voc temperature coefficient loss and the lowest temperature of installation location must be taken into consideration when conducting stringing design for Voc of the PV string.

- The PV modules connected in parallel shall have similar voltage. The Isc temperature coefficient loss and the highest temperature of installation location must be taken into consideration when calculating the Isc of the PV array.
- Please refer to local regulations to identify the suitable system wires sizes, type and temperature derating consideration.
- The cross-sectional area and cable connector current carrying capacity must satisfy the maximum short-circuit of PV system (For a single component, we recommended the cross-sectional area of cables is 4mm² and the rated current of connectors is more than 15A), otherwise cables and connectors will become overheated for large current. Please pay attention to the upper temperature limit of cables of 85°C and connector at 105°C respectively.
- A qualified system designer or integrator should always be consulted.
- Building permits, inspections, and approvals by the local utility operator are deemed required. Before installation, make sure that the connector is well protected and there should be no foreign matter such as soil, sand, and gravel inside the connector. If there is any, it must be cleaned and removed before installation. If the connector is damaged or deformed, the connector must be replaced before use; if there is no spare connector, please contact seraphim in time.
- When the customer makes a series circuit connection, it is necessary to use the identical connector type as PV module to avoid mismatch inflicted PV fire risk. If necessary, the connector on the module can be cut off and replaced with the customer's desired connector.



Do not bend the cables less than 43 mm (1.69 inch) radius. PV cables will be damaged if bending radius less than 43mm.

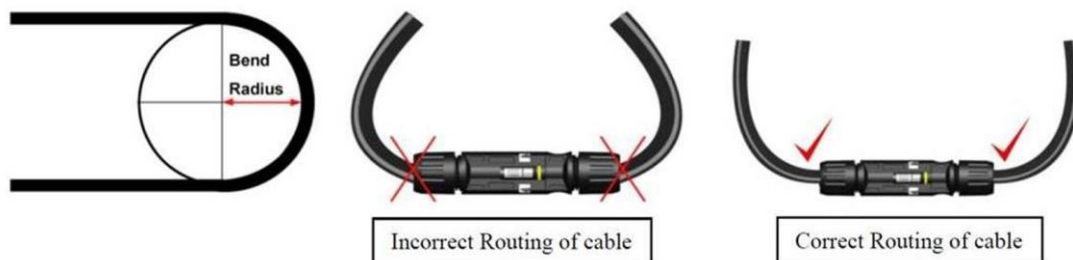

Figure 8 Minimum bending radius of cables

Remark : If jumper/conversion cable is needed, see attachment 1 for details.

4.8 GROUNDING

Any common grounding hardware and components such as nuts, bolts, star washers, split-ring lock washers, flat washers, and other compatible components can be used for grounding or equipotential bonding. Continuity must be ensured in conformance to the manufacturer's grounding instructions.

For grounding and bonding requirements, please refer to country specific national safety and electricity standards.

If grounding is required, use a recommended connector type, or an equivalent, grounding wire.

If grounding is required, the grounding wire must be properly fastened to the module frame to ensure continuity.

When system operates in high humidity and temperature circumstances, transformer-based inverter allowing system negative grounding is highly recommended to mitigate risk of potential induced degradation.

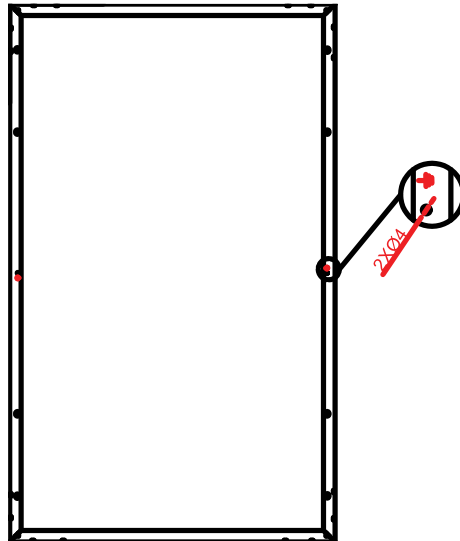

Figure 9 Grounding holes

5 MAINTENANCE

Clean the glass surface of the module regularly with clean water and a soft sponge or cloth. A mild, non-abrasive cleaning agent may be used to remove stubborn dirt.

Caution: abide to the maintenance instructions for all components used in the system, such as support frames, charging regulators, inverters, batteries etc.

5.1 Cleaning

Use a dry mop to sweep away debris and contaminants on the module surface, such as dry floating dust and leaves.

For hardened objects or stains that are tightly attached to the glass surface, such as dirt, bird droppings, and viscous objects, a slightly hard scraper or gauze can be used for scraping, but care must be taken not to use hard abrasive materials to scrape to avoid damaging the glass surface and anti-reflection coating.

For stubborn soiling that cannot be swept away, such as residues of bird droppings, plant juices, or wet soil that are tightly stained onto the glass, photovoltaic cleaning machines need to be used for treatment. The cleaning process generally uses clean water and photovoltaic cleaning brushes for removal. In case of oily contaminants, washing powder or soapy water and other related alcohol based solvents can be used in conjunction with photovoltaic panel cleaning robots to clean the contaminated areas separately.



Figure 10 Tools used for cleaning

5.2 Appearance Inspection of PV Modules

The performance of photovoltaic modules in photovoltaic power plants should be regularly spot-checked, and a comprehensive inspection should be carried out. Modules with serious problems such as glass breakage and severe performance deterioration should be replaced in a timely manner.

5.3 Inspection of Connectors and Cables

Regularly check whether the photovoltaic string connector wiring is in good contact, the circuit cables are intact/crimped sufficiently, there are no short circuit or open circuit phenomena on strings, the cable outer insulation sheath has no sign of cracking, damage, aging, and powdering phenomena. In areas with severe rodent damage, special attention should be paid to cables exposed on the ground to avoid being bitten and damaged by rats. The temperature rise at the MC4 connection joint of the photovoltaic module string is normal, there are no signs of burning at the plug connector, and there are no problems such as poor contact. If any problems occur, please consult a professional for advice.

6 PARAMETERS

The parameters may be updated from time to time, accurate parameters please check out our website at <http://www.seraphim-energy.com> or email to our technical support team at technic@seraphim-energy.com.

[1] REMARK

Module type	Landscape installation	Portrait installation
<p>SRP-XXX-6PA-DG SRP-XXX-6MA-DG/BG SRP-XXX-6PB-DG SRP-XXX-6MB-DG/BG</p>		
<p>SRP-XXX-BPA-DG SRP-XXX-BMA-DG/BG SRP-XXX-BPB-DG SRP-XXX-BMB-DG/BG SRP-XXX-BTB-BG SRP-XXX-BHB-BG</p>		
<p>SRP-XXX-BMZ-DG/BG SRP-XXX-BTZ-BG</p>		
<p>SRP-XXX-BMC-BG SRP-XXX-BTC-BG SRP-XXX-BHC-BG</p>		
<p>SRP-XXX-BMD-BG SRP-XXX-BTD-BG</p>		

Table 11 Schematic diagram of horizontal and vertical installation for different module models

ATTACHMENT 1

INSTRUCTIONS FOR USE OF CONVERSION CABLES

Conversion cables are required to meet any of the following conditions:

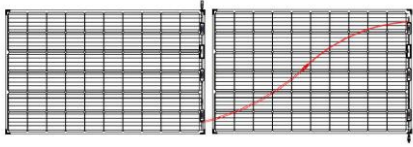
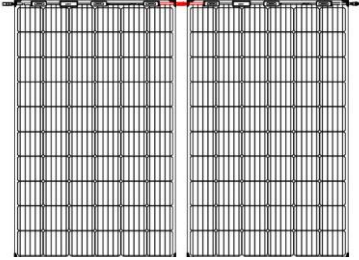
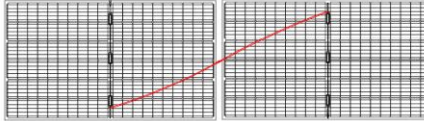
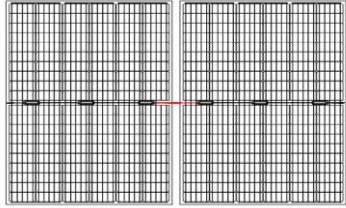
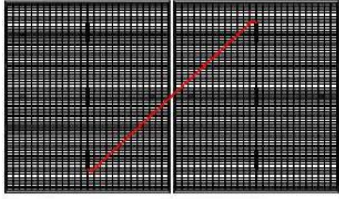
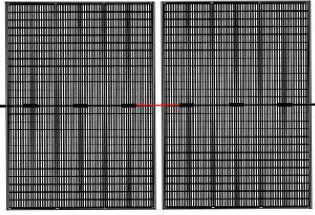
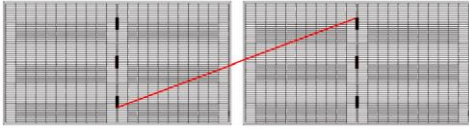
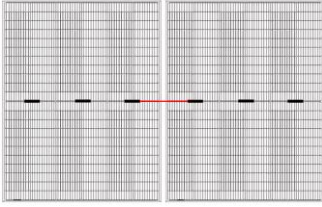
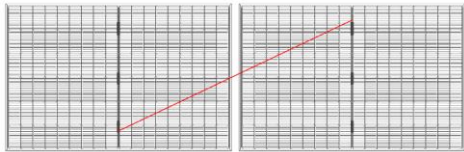
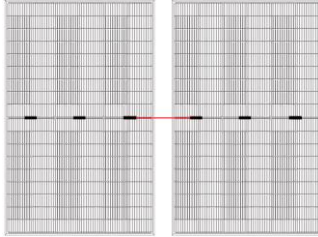
1. When the DC side input terminal of the inverter or combiner box is original MC4.
2. When the manufacturer of inverter or combiner box requires series DC input bus terminal must be MC4.

Inspection before use:

1. Confirm the original MC4 connector of the conversion cable and compatible MC4 connector.
2. Make sure that the connector on the conversion cable is not detached or loose, and the metal core is not skewed or water stained, etc.
3. Confirm that the cable insulation layer of the conversion cable is not damaged, and the cable is not severely bent or twisted.

Installation of conversion cable:

1. The conversion cable installation position: the positive pole of the string is the positive pole of the first component junction box cable in the string, and the negative pole is the negative pole of the last component junction box cable in the string.
2. Insert the positive pole of the string into the negative pole of the conversion cable (compatible) and connect the other positive pole of the conversion cable (original MC4) to the DC positive input terminal of the inverter or combiner box.
3. Insert the negative pole of the string into the positive pole of the conversion cable (compatible) and connect the negative pole of the conversion cable (original MC4) to the DC negative input of the inverter or combiner box.

The schematic diagram is as follows:

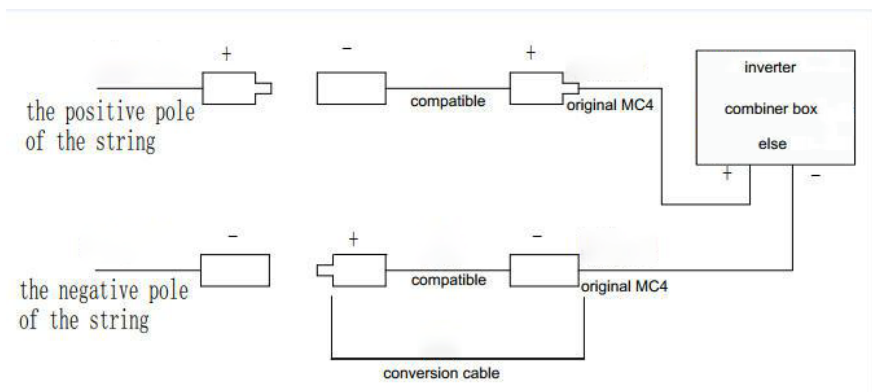

Figure 11 Schematic diagram of wiring installation

Precautions:

1. Make sure that the polarity of the string after connection matches the polarity between the inverter or combiner box.
2. When installing and connecting please strictly follows the schematic diagram, and do not reverse the procedure.
3. Each string on the DC side is limited to one pair of conversion cable wires, and cannot be abused, such as connecting multiple time as though an extension wire.